



Digital Villa VTO
VTO3221E-P
Quick Start Guide

V1.0.0

Cybersecurity Recommendations

Mandatory actions to be taken towards cybersecurity

1. Change Passwords and Use Strong Passwords:

The number one reason systems get “hacked” is due to having weak or default passwords. It is recommended to change default passwords immediately and choose a strong password whenever possible. A strong password should be made up of at least 8 characters and a combination of special characters, numbers, and upper and lower case letters.

2. Update Firmware

As is standard procedure in the tech-industry, we recommend keeping NVR, DVR, and IP camera firmware up-to-date to ensure the system is current with the latest security patches and fixes.

“Nice to have” recommendations to improve your network security

1. Change Passwords Regularly

Regularly change the credentials to your devices to help ensure that only authorized users are able to access the system.

2. Change Default HTTP and TCP Ports:

- Change default HTTP and TCP ports for systems. These are the two ports used to communicate and to view video feeds remotely.
- These ports can be changed to any set of numbers between 1025-65535. Avoiding the default ports reduces the risk of outsiders being able to guess which ports you are using.

3. Enable HTTPS/SSL:

Set up an SSL Certificate to enable HTTPS. This will encrypt all communication between your devices and recorder.

4. Enable IP Filter:

Enabling your IP filter will prevent everyone, except those with specified IP addresses, from accessing the system.

5. Change ONVIF Password:

On older IP Camera firmware, the ONVIF password does not change when you change the system’s credentials. You will need to either update the camera’s firmware to the latest revision or manually change the ONVIF password.

6. Forward Only Ports You Need:

- Only forward the HTTP and TCP ports that you need to use. Do not forward a huge range of numbers to the device. Do not DMZ the device's IP address.
- You do not need to forward any ports for individual cameras if they are all connected to a recorder on site; just the NVR is needed.

7. Disable Auto-Login on SmartPSS:

Those using SmartPSS to view their system and on a computer that is used by multiple people should disable auto-login. This adds a layer of security to prevent users without the appropriate credentials from accessing the system.

8. Use a Different Username and Password for SmartPSS:

In the event that your social media, bank, email, etc. account is compromised, you would not want someone collecting those passwords and trying them out on your video surveillance system. Using a different username and password for your security system will make it more difficult for someone to guess their way into your system.

9. Limit Features of Guest Accounts:

If your system is set up for multiple users, ensure that each user only has rights to features and functions they need to use to perform their job.

10. UPnP:

- UPnP will automatically try to forward ports in your router or modem. Normally this would be a good thing. However, if your system automatically forwards the ports and you leave the credentials defaulted, you may end up with unwanted visitors.
- If you manually forwarded the HTTP and TCP ports in your router/modem, this feature should be turned off regardless. Disabling UPnP is recommended when the function is not used in real applications.

11. SNMP:

Disable SNMP if you are not using it. If you are using SNMP, you should do so only temporarily, for tracing and testing purposes only.

12. Multicast:

Multicast is used to share video streams between two recorders. Currently there are no known issues involving Multicast, but if you are not using this feature, deactivation can enhance your network security.

13. Check the Log:

If you suspect that someone has gained unauthorized access to your system, you can check the system log. The system log will show you which IP addresses were used to login to your system and what was accessed.

14. Physically Lock Down the Device:

Ideally, you want to prevent any unauthorized physical access to your system. The best way to achieve this is to install the recorder in a lockbox, locking server rack, or in a room that is behind a lock and key.

15. Connect IP Cameras to the PoE Ports on the Back of an NVR:

Cameras connected to the PoE ports on the back of an NVR are isolated from the outside world and cannot be accessed directly.

16. Isolate NVR and IP Camera Network

The network your NVR and IP camera resides on should not be the same network as your public computer network. This will prevent any visitors or unwanted guests from getting access to the same network the security system needs in order to function properly.

Regulatory Information

The regulatory information herein might vary according to the model you purchased. Some information is only applicable for the country or region where the product is sold.

FCC Information



CAUTION

Changes or modifications not expressly approved by the party responsible for compliance could void the user's authority to operate the equipment.

FCC conditions:

This device complies with part 15 of the FCC Rules. Operation is subject to the following two conditions:

- This device may not cause harmful interference.
- This device must accept any interference received, including interference that may cause undesired operation.

FCC compliance:

This equipment has been tested and found to comply with the limits for a digital device, pursuant to part 15 of the FCC Rules. This equipment generate, uses and can radiate radio frequency energy and, if not installed and used in accordance with the instructions, may cause harmful interference to radio communication.




- For class A device, these limits are designed to provide reasonable protection against harmful interference in a commercial environment. Operation of this equipment in a residential area is likely to cause harmful interference in which case the user will be required to correct the interference at his own expense.
- For class B device, these limits are designed to provide reasonable protection against harmful interference in a residential installation. However, there is no guarantee that interference will not occur in a particular installation. If this equipment does cause harmful interference to radio or television reception, which can be determined by turning the equipment off and on, the user is encouraged to try to correct the interference by one or more of the following measures:
 - Reorient or relocate the receiving antenna.
 - Increase the separation between the equipment and receiver.
 - Connect the equipment into an outlet on a circuit different from that to which the receiver is connected.
 - Consult the dealer or an experienced radio/TV technician for help.

General

This Guide introduces the structure, mounting process, and basic configuration of the device.

Safety Instructions

The following categorized signal words with defined meaning might appear in the Guide.

Signal Words	Meaning
 WARNING	Indicates a medium or low potential hazard which, if not avoided, could result in slight or moderate injury.
 CAUTION	Indicates a potential risk which, if not avoided, could result in property damage, data loss, lower performance, or unpredictable result.
 NOTE	Provides additional information as the emphasis and supplement to the text.

Revision History

No.	Version	Revision Content	Release Date
1	V1.0.0	First release	November 2018

Privacy Protection Notice

As the device user or data controller, you might collect personal data of others such as face, fingerprints, car plate number, Email address, phone number, GPS and so on. You need to be in compliance with the local privacy protection laws and regulations to protect the legitimate rights and interests of other people by implementing measures include but not limited to: providing clear and visible identification to inform data subject the existence of surveillance area and providing related contact.

About the Guide

- The Guide is for reference only. If there is inconsistency between the Guide and the actual product, the actual product shall prevail.
- We are not liable for any loss caused by the operations that do not comply with the Guide.
- The Guide would be updated according to the latest laws and regulations of related regions. For detailed information, see the paper manual, CD-ROM, QR code or our official website. If there is inconsistency between paper manual and the electronic version, the electronic version shall prevail.

- All the designs and software are subject to change without prior written notice. The product updates might cause some differences between the actual product and the Guide. Please contact the customer service for the latest program and supplementary documentation.
- There still might be deviation in technical data, functions and operations description, or errors in print. If there is any doubt or dispute, please refer to our final explanation.
- Upgrade the reader software or try other mainstream reader software if the Guide (in PDF format) cannot be opened.
- All trademarks, registered trademarks and the company names in the Guide are the properties of their respective owners.
- Please visit our website, contact the supplier or customer service if there is any problem occurred when using the device.
- If there is any uncertainty or controversy, please refer to our final explanation.

Important Safeguards and Warnings

The following description is the correct application method of the device. Please read the manual carefully before use, in order to prevent danger and property loss. Strictly conform to the manual during application and keep it properly after reading.

Operating Requirement

- Please don't place and install the device in an area exposed to direct sunlight or near heat generating device.
- Please don't install the device in a humid, dusty or fuliginous area.
- Please keep its horizontal installation, or install it at stable places, and prevent it from falling.
- Please don't drip or splash liquids onto the device; don't put on the device anything filled with liquids, in order to prevent liquids from flowing into the device.
- Please install the device at well-ventilated places; don't block its ventilation opening.
- Use the device only within rated input and output range.
- Please don't dismantle the device arbitrarily.
- Please transport, use and store the device within allowed humidity and temperature range.

Power Requirement

- The product shall use electric wires (power wires) recommended by this area, which shall be used within its rated specification!
- Please use power supply that meets SELV (safety extra low voltage) requirements, and supply power with rated voltage that conforms to Limited Power Source in IEC60950-1. For specific power supply requirements, please refer to device labels.
- Appliance coupler is a disconnecting device. During normal use, please keep an angle that facilitates operation.

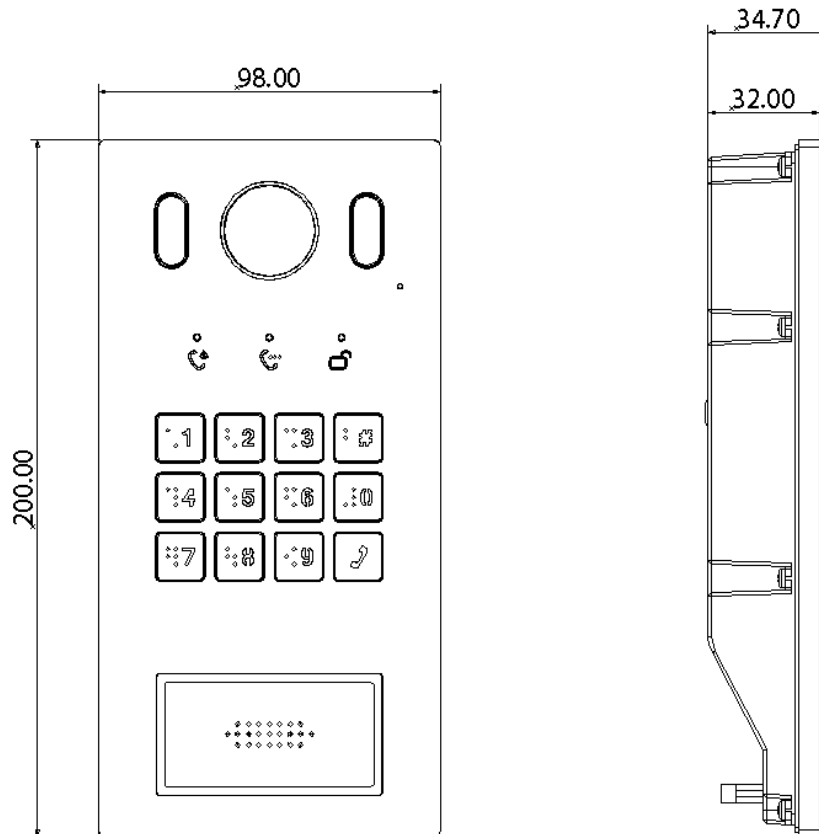
Table of Contents

Cybersecurity Recommendations	II
Regulatory Information	V
Foreword	VI
Important Safeguards and Warnings	VIII
1 Appearance	1
1.1 Dimension	1
1.2 Front Panel	1
1.3 Rear Panel	3
2 Installation	4
2.1 Installation Requirement	4
2.1.1 Notice	4
2.1.2 Guidance	4
2.2 Connecting Cable	4
2.2.1 RS-485 Port	4
2.2.2 Wiegand Port	5
2.2.3 Door Lock Port	5
2.2.4 Alarm I/O and Power Port	7
2.3 Installing VTO	8
2.3.1 Installing with Mounting Box	8
2.3.2 Installing with Enclosure	9
3 Configuration	10
3.1 Configuration Process	10
3.2 Config Tool	10
3.3 Configuring VTO	10
3.3.1 Initialization	10
3.3.2 Configuring VTO Number	11
3.3.3 Configuring Network Parameters	12
3.3.4 Configuring SIP Server	13
3.3.5 Adding VTO Devices	14
3.3.6 Adding Room Number	15
3.4 Verifying Configuration	17
3.4.1 Calling VTH from VTO	17
3.4.2 Doing Monitor from VTH	17
4 Operating VTO	19
4.1 Call Function	19
4.1.1 Calling single VTH	19
4.1.2 Calling Multiple VTH Devices	19
4.1.3 Calling Management Center	19
4.2 Unlock Function	19
4.2.1 Unlock with Password	19
4.2.2 Unlock with IC Card	19

4.2.3 Unlock From VTH.....	19
4.2.4 Unlock From the Management Center	20
5 Connecting Mobile Phone App.....	21
Appendix 1 Packing List.....	25

1.1 Dimension

Figure 1-1 Dimension (mm)



1.2 Front Panel

For the description of the front panel, see Table 1-1.

Figure 1-2 Front panel

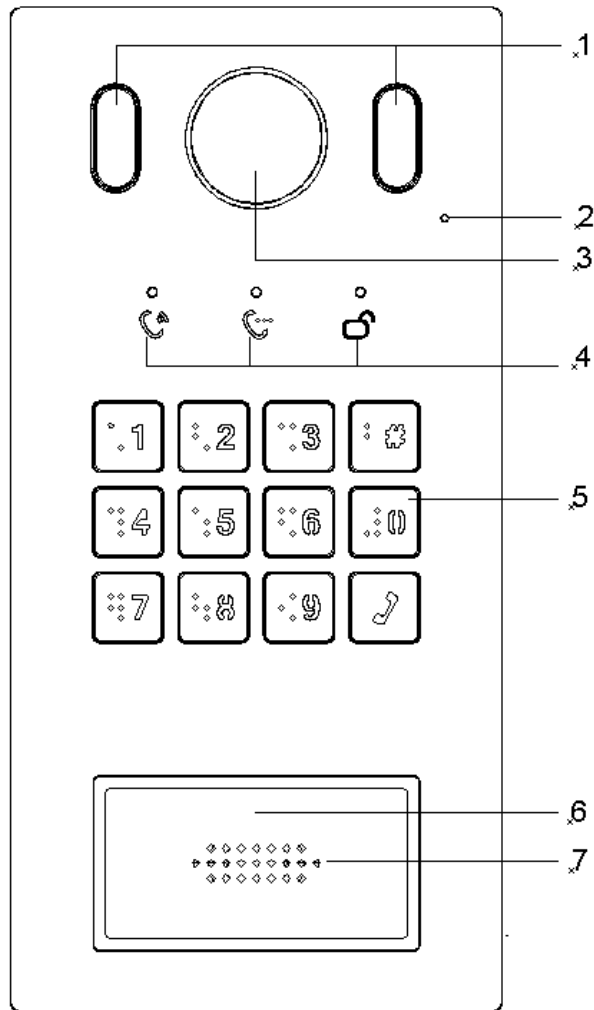


Table 1-1 Front panel description

No.	Name	Description
1	Fill light	Provides extra light for the camera.
2	MIC	Inputs audio.
3	Camera	Monitors door area.
4	Indicators	Includes calling, talking, and unlock indicators.
5	Dialing area	Press to operate the VTO.
6	Access card reader	Recognizes access card and unlock the door.
7	Speaker	Outputs audio.

1.3 Rear Panel

Figure 1-3 VTO6221E-P

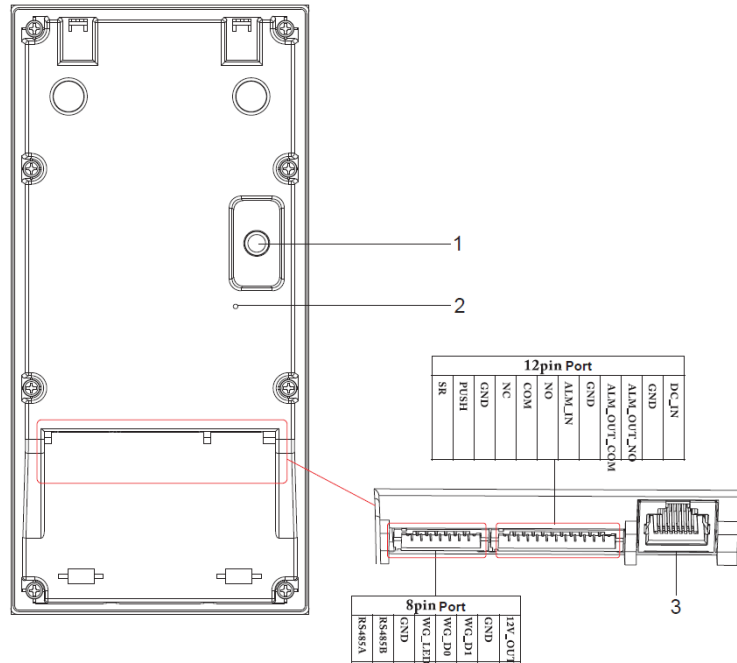


Table 1-2 Rear panel description

No.	Name	Description
1	Tamper switch	The VTO would make alarm sound if it is being removed from the wall by force, and the alarm will also be sent to the management center.
2	Reset button	Press and hold the button for 10 s to reset the VTO.
3	Ethernet port	Connects to the network with Ethernet cable.

2.1 Installation Requirement

2.1.1 Notice

- Do not install the VTO to places with condensation, high temperature, grease or dust, chemical corrosion, direct sunlight, or zero shelter.
- The installation and adjustment must be finished by professional crew, and do not disassemble the VTO.

2.1.2 Guidance

See Figure 2-1 for the reference of the installation position, and for the VTO horizontal viewing angle, see Table 2-1.

Figure 2-1 Installation position reference

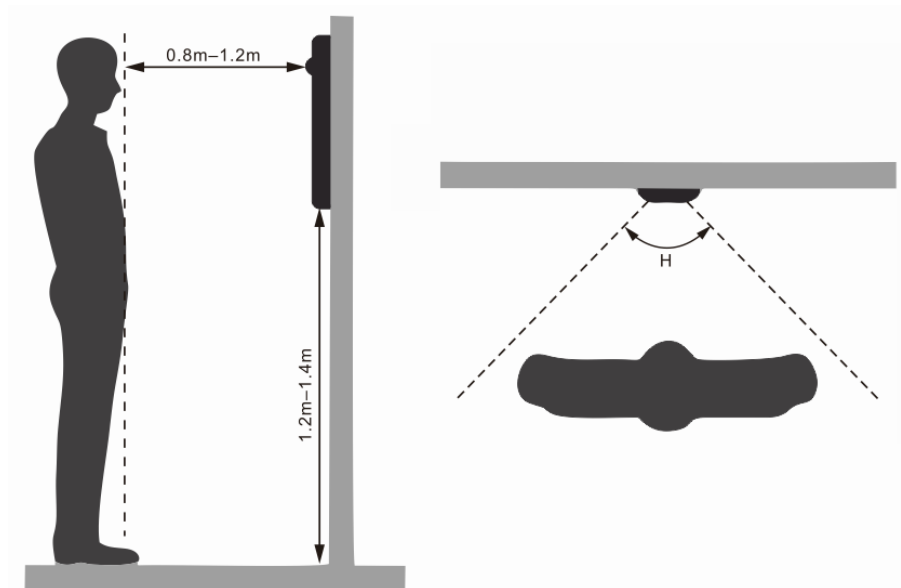


Table 2-1 Horizontal viewing angle

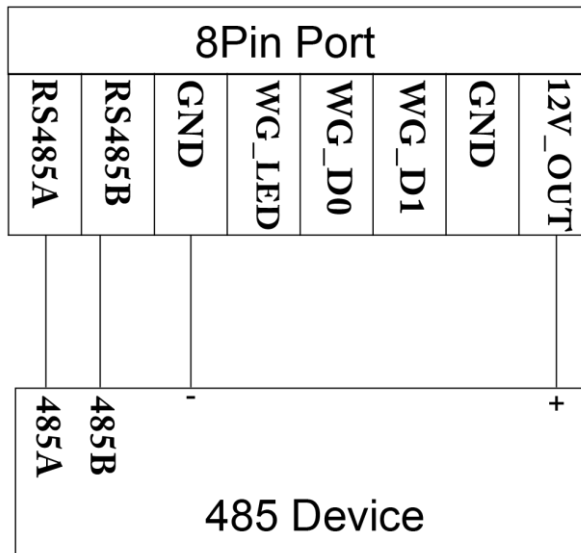
Model	Angle of View (H)
VTO6221E-P	75°

2.2 Connecting Cable

2.2.1 RS-485 Port

This port can be used to connect to RS-485 devices. See Figure 2-2.

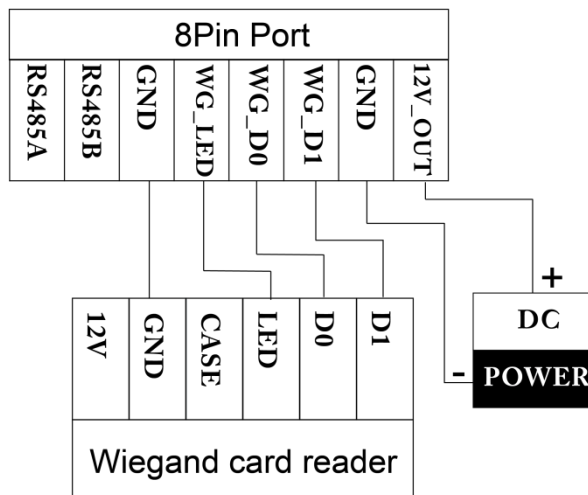
Figure 2-2 RS-485 port



2.2.2 Wiegand Port

The Wiegand port can be used to connect to the Wiegand card reader. See Figure 2-3.

Figure 2-3 Wiegand port



2.2.3 Door Lock Port

This port can be used to connect to door locks, and the connection method varies with different locks. See Figure 2-4, Figure 2-5, and Figure 2-6.

Figure 2-4 Electronic lock connection

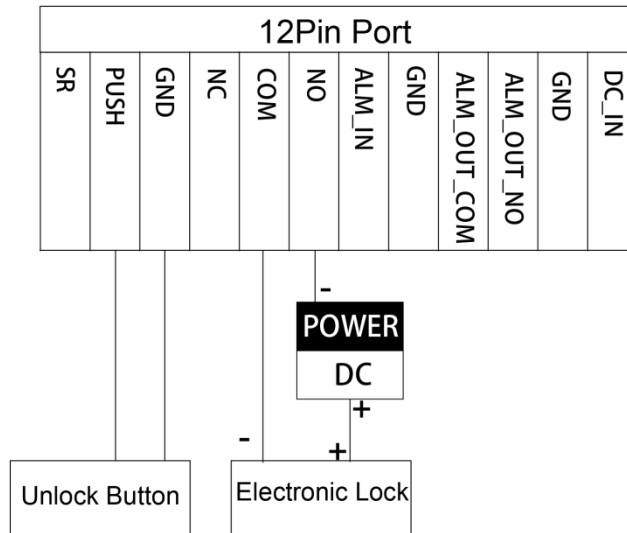


Figure 2-5 Magnetic lock connection

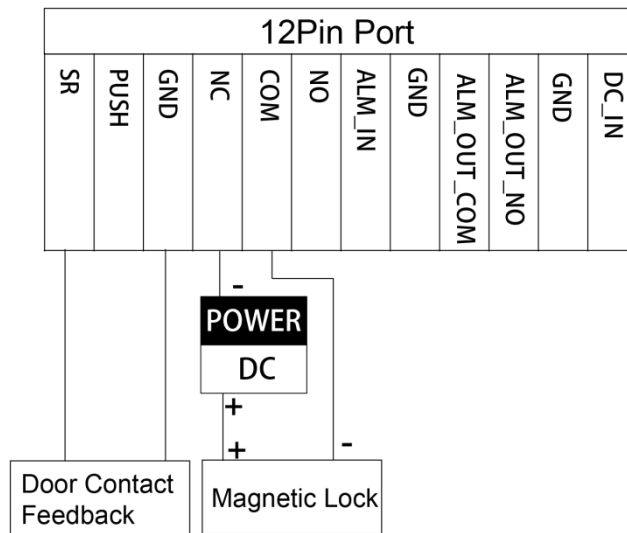
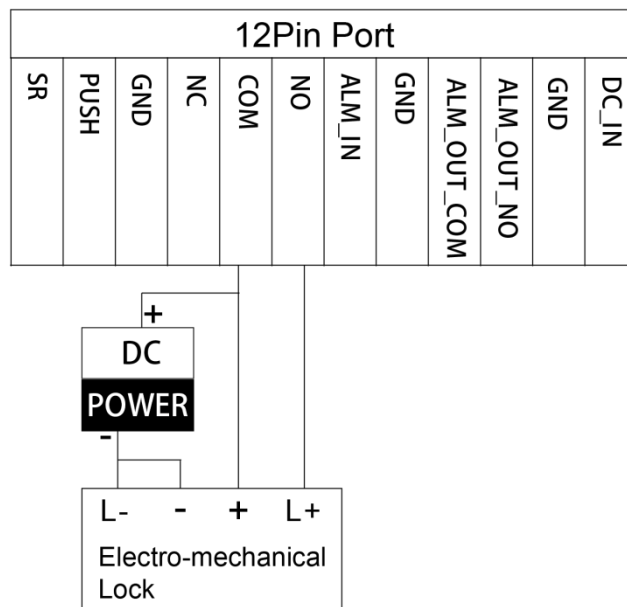


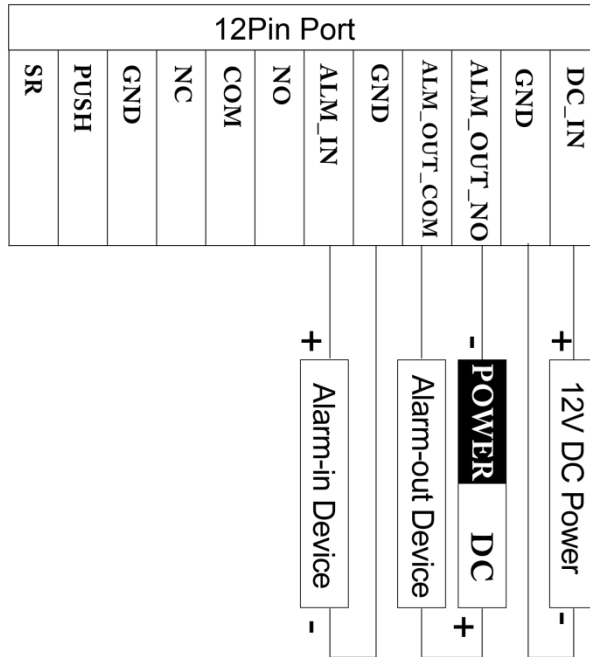
Figure 2-6 Electro-mechanical lock connection



2.2.4 Alarm I/O and Power Port

This port can be used to connect 1 alarm-in device and 1 alarm-out device, and one 12 DC power. See Figure 2-7.

Figure 2-7 Alarm I/O and power Port



2.3 Installing VTO

2.3.1 Installing with Mounting Box

Figure 2-8 Wall mounted

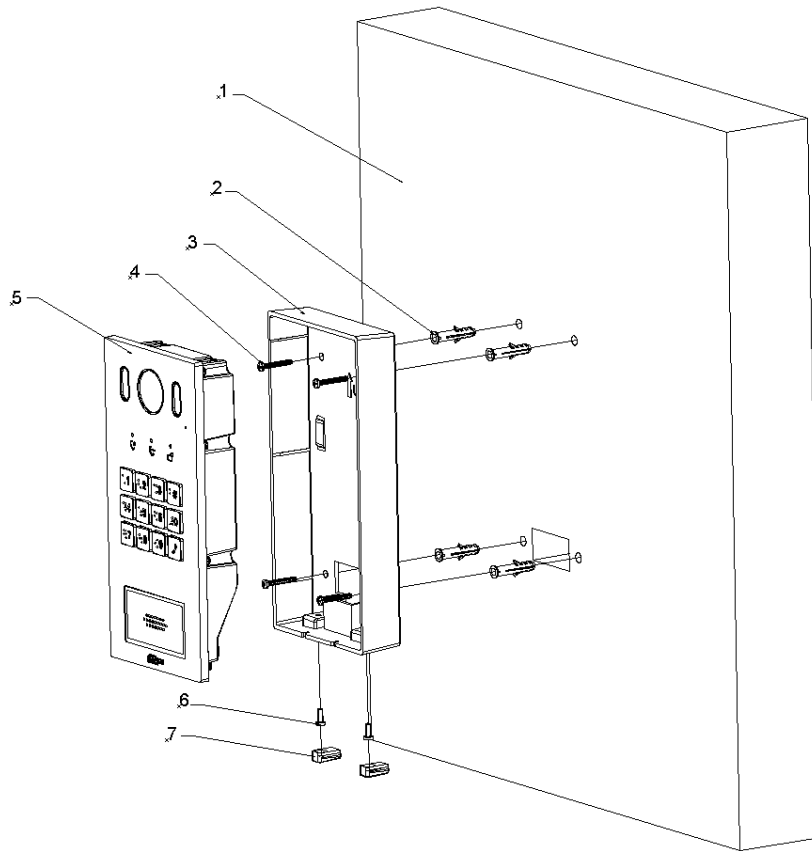


Table 2-2 Item list

No.	Item	No.	Item	No.	Item	No.	Item
1	Wall	2	Expansion tube	3	Mounting box	4	ST4×18 screw
5	VTO	6	M3×8 screw	7	Rubber plug	—	—

Step 1 Drill screw holes in the wall according to the position of the screw holes in the mounting box, and then put the expansion tubes in the screw holes.

Step 2 Pull the reserved cables through the cable hole on the mounting box and connect them to the ports on the VTO rear panel. See "2.2 Connecting Cable."

Step 3 Fix the mounting box on the wall with the ST4×18 screws.

Step 4 Fix the VTO in the mounting box with the M3×8 screws.

Step 5 Put the rubber plugs in the holes on the bottom of the mounting box.

2.3.2 Installing with Enclosure

Figure 2-9 Installing with enclosure

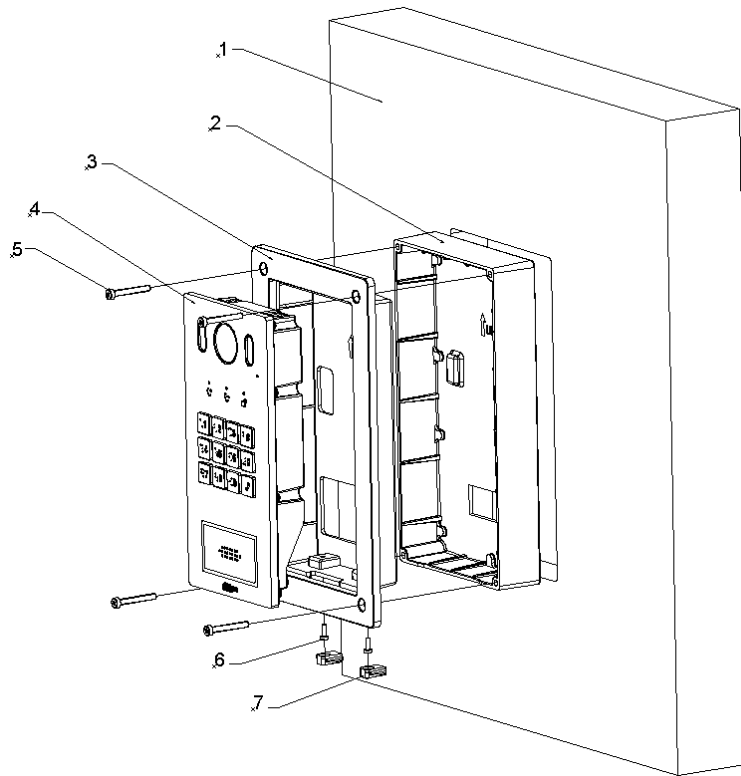


Table 2-3 Item list

No.	Item	No.	Item	No.	Item	No.	Item
1	Wall	2	Mounting box	3	Enclosure	4	VTO
5	ST4×25 screw	6	M3 screw	7	Rubber plug	—	—

Step 1 Cut an opening with the size of the mounting box on the wall.

Step 2 Pull the reserved cables through the cable hole on the mounting box, and then fix the mounting box in the wall with cement.

Step 3 Connect the cables to the ports on the VTO rear panel through the enclosure. See "2.2 Connecting Cable."

Step 4 Fix the VTO in the enclosure with the M3 screws, and then put sealant between the VTO and the enclosure.

Step 5 Fix the VTO and the enclosure in the mounting box with the ST4×25 screws.

This chapter introduces how to initialize, connect, and make primary configurations to the VTO and VTH devices to realize basic functions, including device management, calling, and monitoring. For more detailed configuration, see the user's Manual.

3.1 Configuration Process



Before configuration, check every device and make sure there is no short circuit or open circuit in the circuits.

Step 1 Plan IP address for every device, and also plan the unit number and room number you need.

Step 2 Configure VTO. See "3.3 Configuring VTO."

- 1) Initialize VTO. See "3.3.1 Initialization."
- 2) Configure VTO number. See "3.3.2 Configuring VTO Number."
- 3) Configure VTO network parameters. See "3.3.3 Configuring Network Parameters."
- 4) Configure SIP Server. See "3.3.4 Configuring SIP Server."
- 5) Add VTO devices to the SIP server. See "3.3.5 Adding VTO Devices."
- 6) Add room number to the SIP server. See "3.3.6 Adding Room Number."

Step 3 Configure VTH. See the VTH users' manual.

Step 4 Verify Configuration. See "3.4 Verifying Configuration."

3.2 Config Tool

You can download the "ConfigTool" and perform device initialization, IP address modification and system upgrading for multiple devices at the same time. For the detailed information, see the corresponding user's manual.

3.3 Configuring VTO

Connect the VTO to your PC with network cable, and for first time login, you need to create a new password for the web interface.

3.3.1 Initialization

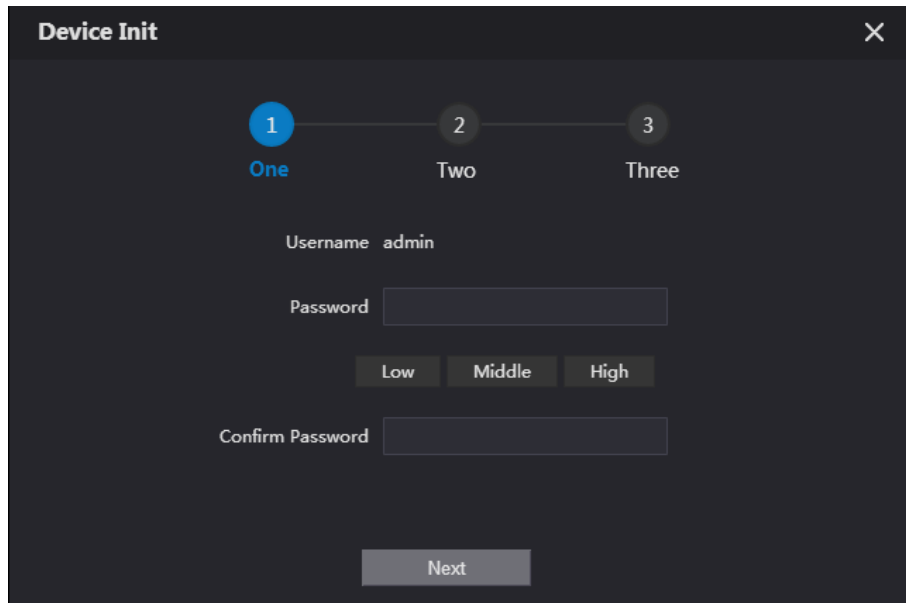
The default IP address of VTO is 192.168.1.110, and make sure the PC is in the same network segment as the VTO.

Step 1 Connect the VTO to power source, and then boot it up.

Step 2 Open the internet browser on the PC, then enter the default IP address of the VTO in the address bar, and then press Enter.

The **Device Init** interface is displayed. See Figure 3-1.

Figure 3-1 Device initialization



Step 3 Enter and confirm the password, and then click **Next**.

The Email setting interface is displayed.

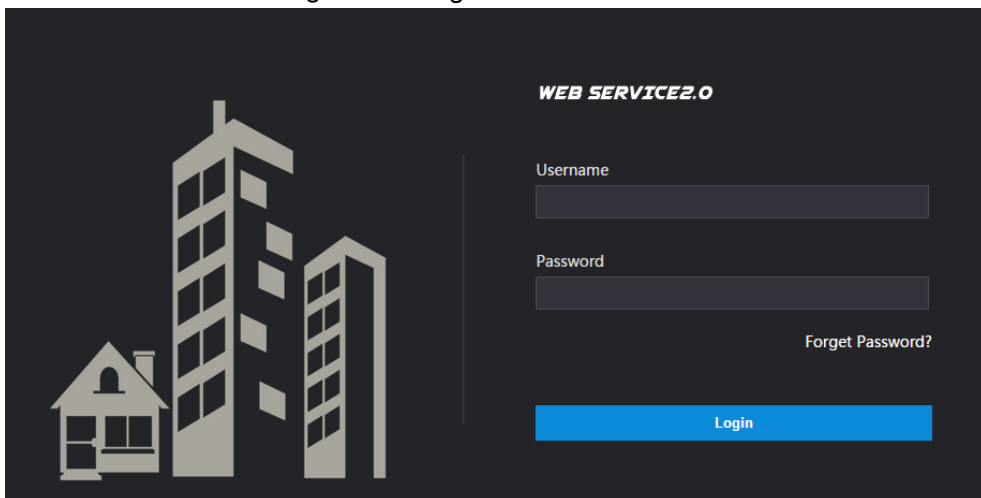
Step 4 Select the **Email** check box, and then enter your Email address. This Email address can be used to reset the password, and it is recommended to finish this setting.

Step 5 Click **Next**. The initialization succeeded.

Step 6 Click **OK**.

The login interface is displayed. See Figure 3-2.

Figure 3-2 Login interface



3.3.2 Configuring VTO Number

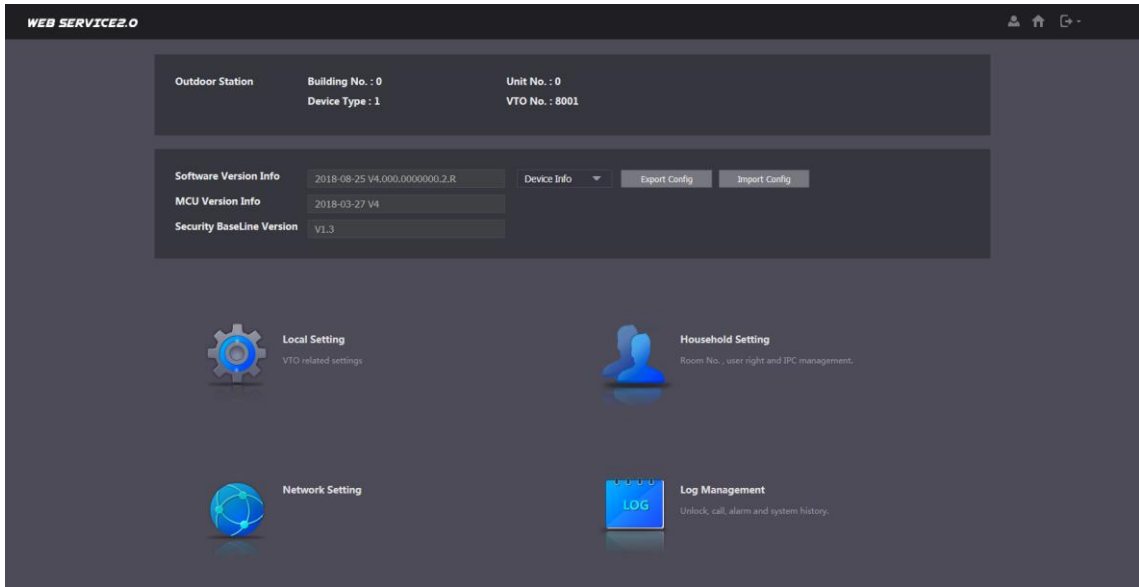
The VTO number can be used to differentiate each VTO, and it is normally configured according to unit or building number.



- You can change the number of a VTO when it is not working as SIP server.
- The VTO number can contain 5 numbers at most, and it cannot be the same with any room number.

Step 1 Log in the web interface of the VTO, and then the main interface is displayed. See Figure 3-3.

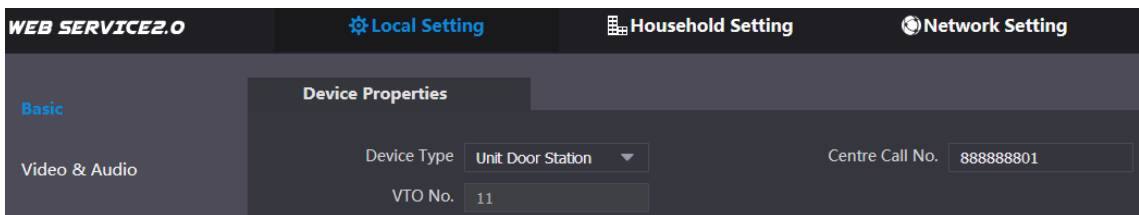
Figure 3-3 Main interface



Step 2 Select Local Setting > Basic.

The device properties are displayed. See Figure 3-4.

Figure 3-4 Device properties



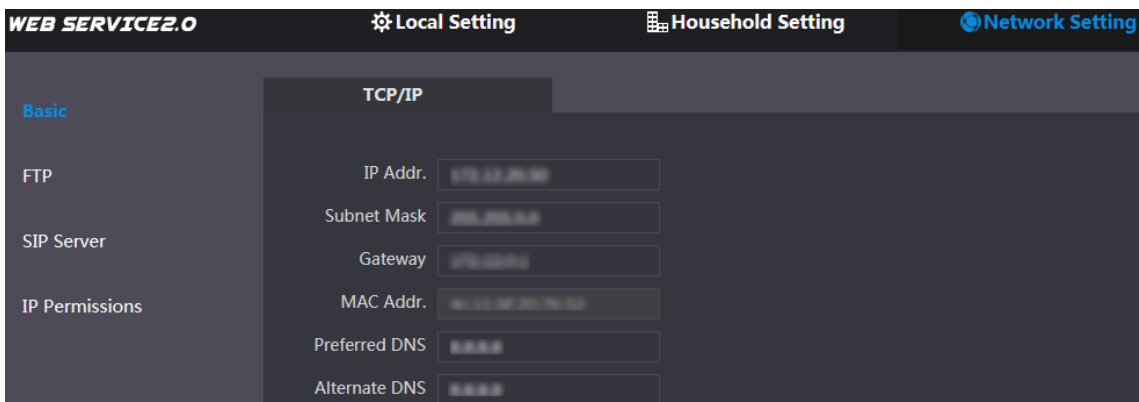
Step 3 In the **VTO No.** input box, enter the VTO number you planned for this VTO, and then click **Confirm** to save.

3.3.3 Configuring Network Parameters

Step 1 Select Network Setting > Basic.

The TCP/IP information is displayed. See Figure 3-5.

Figure 3-5 TCP/IP information



Step 2 Enter the network parameters you planned, and then click **Save**.

The VTO will reboot, and you need to modify the IP address of your PC to the same network segment with the VTO to log in again.

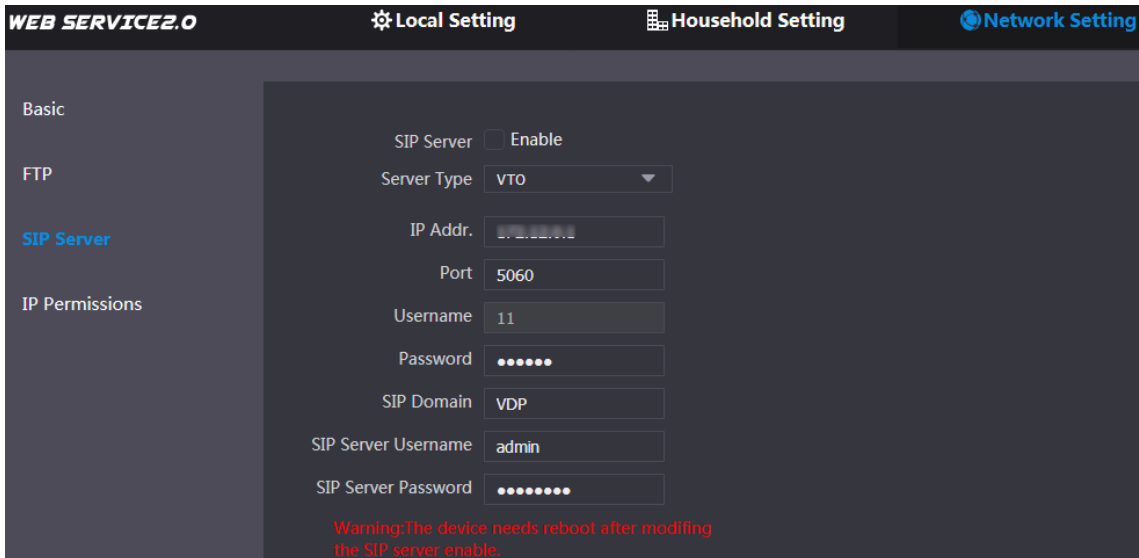
3.3.4 Configuring SIP Server

The SIP server is required in the network to transmit intercom protocol, and then all the VTO and VTH devices connected to the same SIP server can make video call between each other. You can use VTO device or other servers as SIP server.

Step 1 Select **Network Setting > SIP Server**.

Step 2 The **SIP Server** interface is displayed. See Figure 3-6.

Figure 3-6 SIP server



Step 3 Select the server type you need.

- If the VTO you are visiting works as SIP server
Select the **Enable** check box at **SIP Server**, and then click **Save**.
The VTO will reboot, and after rebooting, you can then add VTO and VTH devices to this VTO. See the details in "3.3.5 Adding VTO Devices" and "3.3.6 Adding Room Number."



If the VTO you are visiting does not work as SIP server, do not select the **Enable** check box at **SIP Server**, otherwise the connection will fail.

- If other VTO works as SIP server
Select **VTO** in the **Server Type** list, and then configure the parameters. See Table 3-1.

Table 3-1 SIP server configuration

Parameter	Description
IP Addr.	The IP address of the VTO which works as SIP server.
Port	5060
Username	Keep the default value.
Password	
SIP Domain	VDP
SIP Server Username	The user name and password for the web interface of the SIP server.
SIP Server Password	

- If other servers work as SIP server

Select the server type you need in the **Server Type** list, and then see the corresponding manual for the detailed configuration.

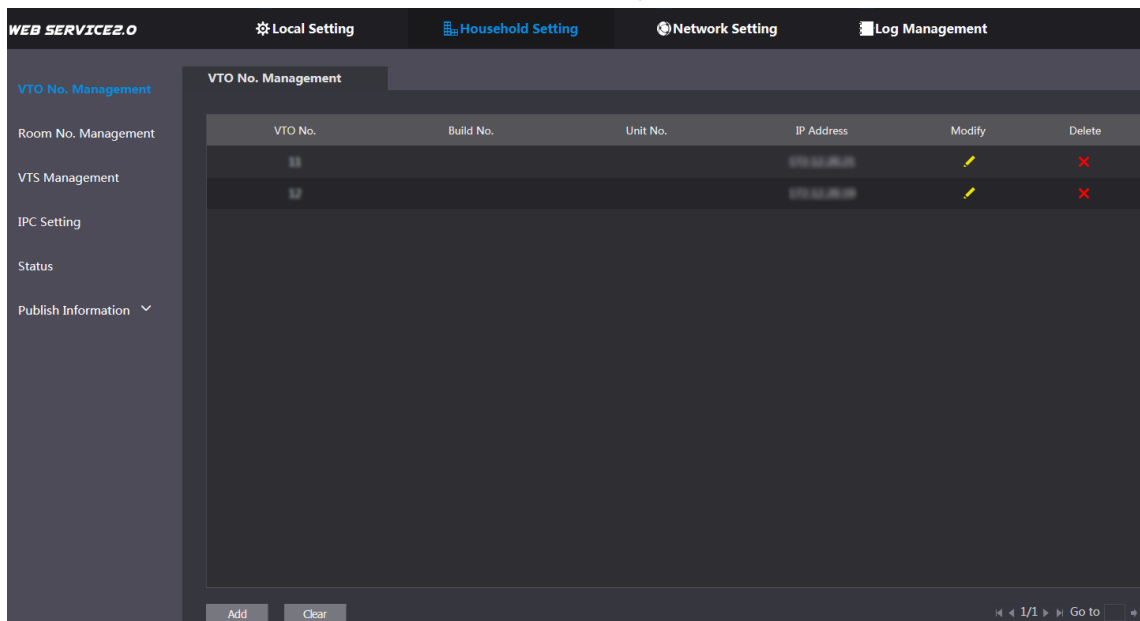
3.3.5 Adding VTO Devices

You can add VTO devices to the SIP server, and all the VTO devices connected to the same SIP server can make video call between each other. This section applies to the condition in which a VTO device works as SIP server, and if you are using other servers as SIP server, see the corresponding manual for the detailed configuration.

Step 1 Log in the web interface of the SIP server, and then select **Household Setting > VTO No. Management**.

The **VTO No. Management** interface is displayed. See Figure 3-7.

Figure 3-7 VTO No. management



Step 2 Click **Add**.

The **Add** interface is displayed. See Figure 3-8.

Figure 3-8 Add VTO

The 'Add' form is a modal window with a close button (X) in the top right corner. It contains the following fields:

- Rec No.
- Register Password
- Build No.
- Unit No.
- IP Address
- Username
- Password

At the bottom of the form, there are 'Save' and 'Cancel' buttons.

Step 3 Configure the parameters, and be sure to add the SIP server itself too. See Table 3-2.

Table 3-2 Add VTO configuration

Parameter	Description
Rec No.	The VTO number you configured for the target VTO. See the details in "3.3.2 Configuring VTO Number."
Register Password	Keep default value.
Build No.	Available only when other servers work as SIP server.
Unit No.	
IP Address	The IP address of the target VTO.
Username	The user name and password for the web interface of the target VTO.
Password	

Step 4 Click **Save**.

3.3.6 Adding Room Number

You can add the planned room number to the SIP server, and then configure the room number on VTH devices to connect them to the network. This section applies to the condition in which a VTO device works as SIP server, and if you use other servers as SIP server, see the corresponding manual for the detailed configuration.

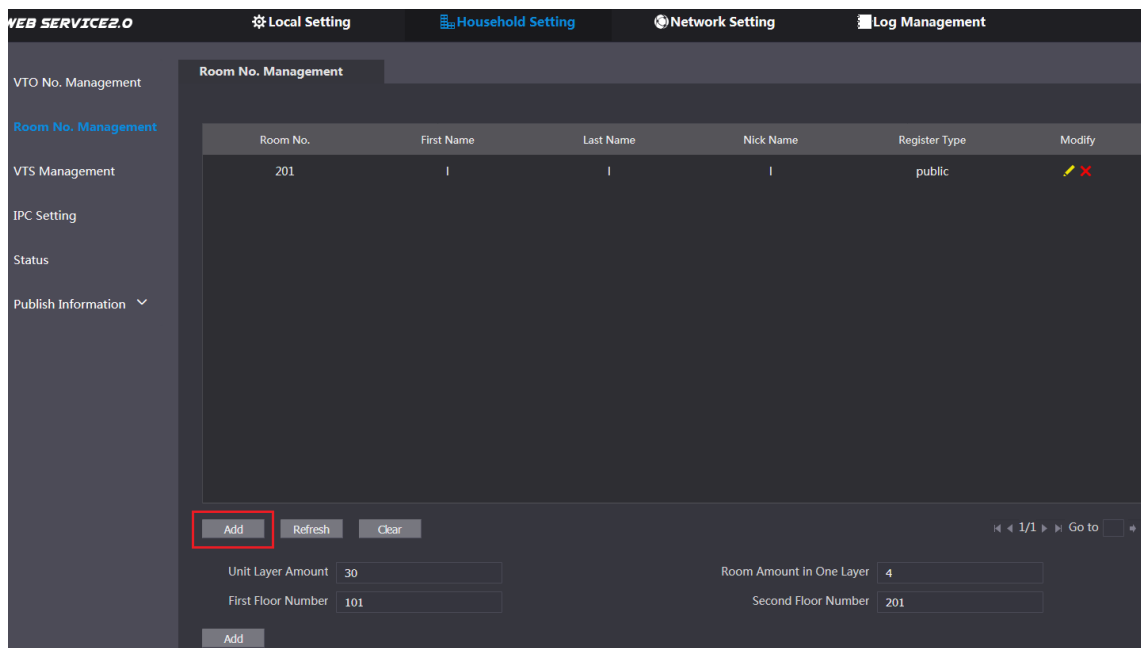


The room number can contain 6 digits of numbers or letters or their combination at most, and it cannot be the same with any VTO number.

Step 1 Log in the web interface of the SIP server, and then select **Household Setting > Room No. Management**.

The **Room No. Management** interface is displayed. See Figure 3-9.

Figure 3-9 Room No. management




Step 2 You can add single room number or do it in batch.

- Adding single room number
 - 1) Click the **Add** at the mid lower position. See Figure 3-9. The **Add** interface is displayed. See Figure 3-10.

Figure 3-10 Add single room number

2) Configure room information. See Table 3-3.

Table 3-3 Room information

Parameter	Description
First Name	Enter the information you need to differentiate each room.
Last Name	
Nick Name	
Room No.	<p>The room number you planned.</p>  <ul style="list-style-type: none"> If you use multiple VTH devices, the room number of the master VTH should be "room number#0", and the room number of the extension VTH should be "room number#1", "room number#2", and so on. You can have 10 extension VTH devices at most for one master VTH.
Register Type	Select public , and local is reserved for future use.
Register Password	Keep the default value.

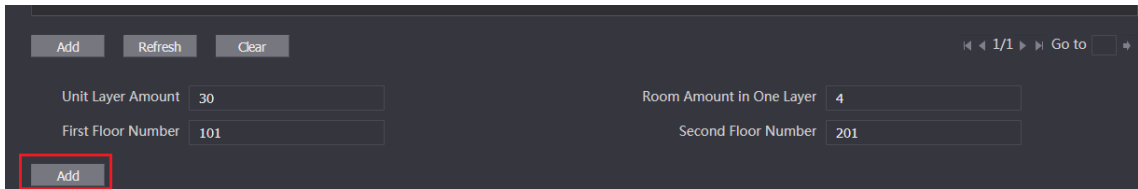
3) Click **Save**.

The added room number is displayed. Click  to modify room information, and click

 to delete a room.

- Adding room number in batch
- 1) Configure the **Unit Layer Amount**, **Room Amount in One Layer**, **First Floor Number**, and **Second Floor Number** according to the actual condition.
 - 2) Click the **Add** at the bottom position. See Figure 3-11

Figure 3-11 Add in batch




All the added room numbers are displayed. Click **Refresh** to view the latest status, and click **Clear** to delete all the room numbers.

3.4 Verifying Configuration

3.4.1 Calling VTH from VTO

Step 1 Dial room number on the VTO.

Step 2 Press .

The VTO is calling the VTH. See Figure 3-12.

Figure 3-12 Call screen



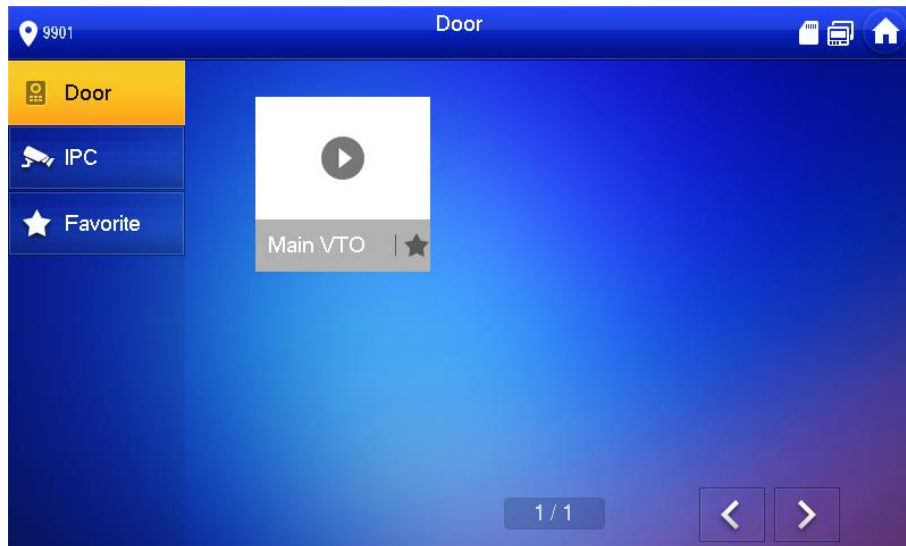
Step 3 Tap  on the VTH to answer the call.

3.4.2 Doing Monitor from VTH

Step 1 In the main interface of the VTH, select **Monitor > Door**.

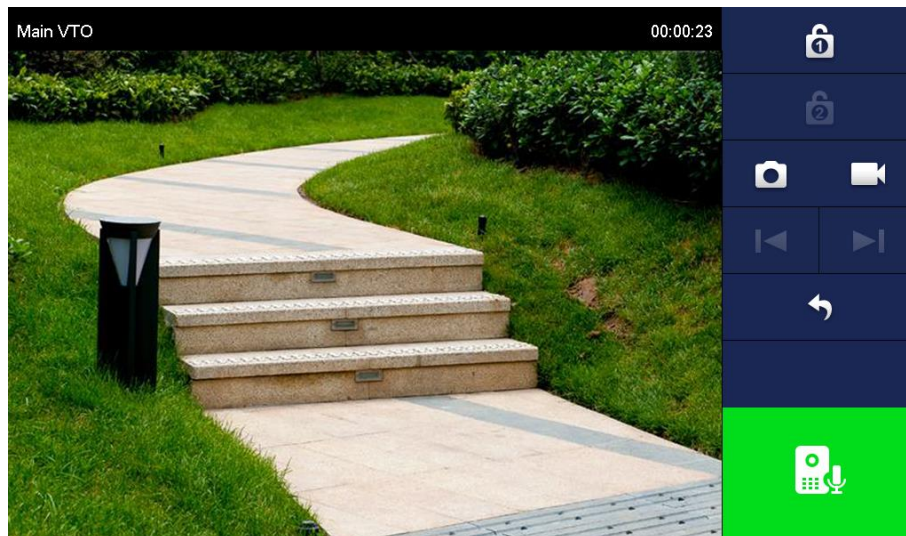
Step 2 The **Door** interface is displayed. See Figure 3-13.

Figure 3-13 Door



Step 3 Select the VTO you need to do monitor.
The monitor screen is displayed. See Figure 3-14.

Figure 3-14 Monitor screen



4 Operating VTO

4.1 Call Function

4.1.1 Calling single VTH

See "3.4.1 Calling VTH from VTO."

4.1.2 Calling Multiple VTH Devices

If the VTO you are visiting works as SIP server, and there are multiple VTH devices being used, when you call the master VTH, all the extension VTH devices would also receive the call.

Before calling, be sure to:

- Enable **Group Call** in **Local Setting > Basic**. See the VTO user's manual.
- Add master VTH and the extension VTH. See "3.3.6 Adding Room Number."

4.1.3 Calling Management Center

Press  on the VTO.

4.2 Unlock Function

4.2.1 Unlock with Password

Step 1 Press  on the VTO.

Step 2 Input unlock password.

Step 3 Press  again.

4.2.2 Unlock with IC Card

Swipe the authorized access card at the access card area of the VTO to open the door.

4.2.3 Unlock From VTH

You can tap the unlock button on VTH to unlock the door when VTO and VTH are having phone call or you are doing monitor.

4.2.4 Unlock From the Management Center

You can unlock the door from the management center when VTO is calling the management center, VTO and the management center are having phone call, or you are doing monitor from the management center.

5

Connecting Mobile Phone App

You can download the mobile phone app, and then add your villa VTO to the app. When someone is calling you from the villa VTO, there will be push message on your phone, and you can talk to the visitor or unlock the door remotely on your phone.

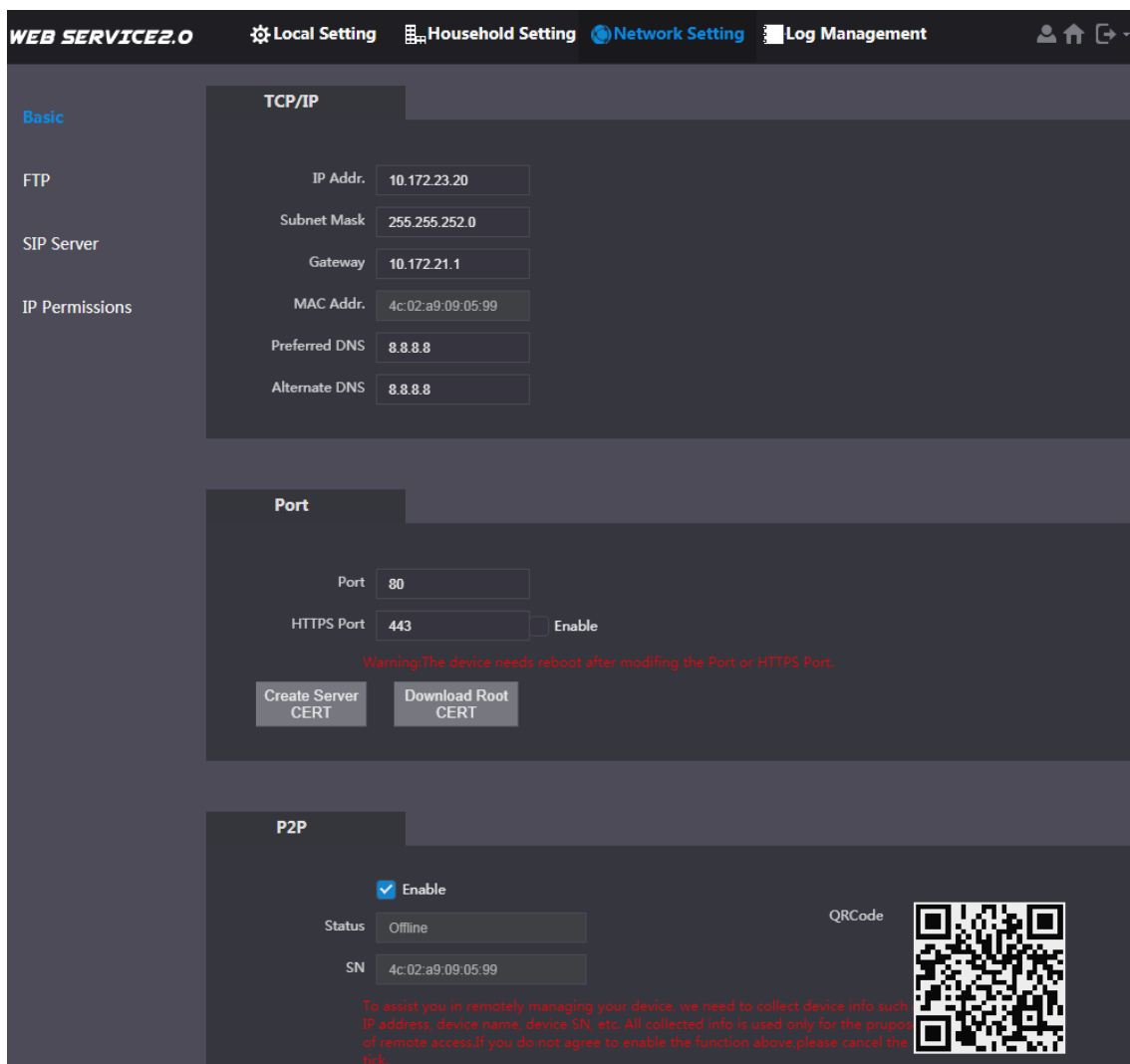
Step 1 Scan the following QR code to download and install the app.

Or you can go to the web, select Network Setting > Basic > P2P, enable the P2P, and then scan the QR code at the bottom left corner of the interface to view information. See Figure 5-1 and Figure 5-2.

Figure 5-1

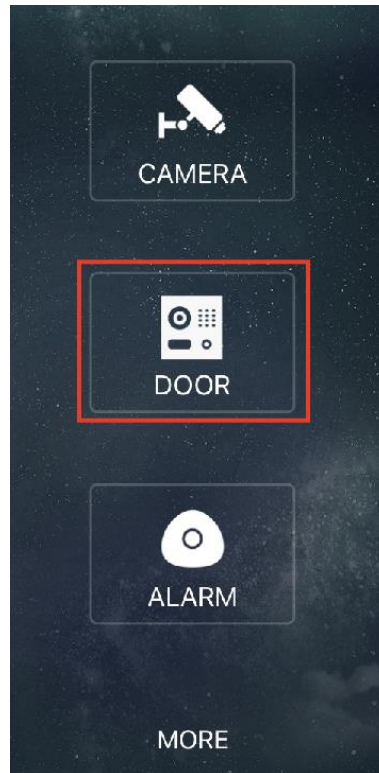


Figure 5-2



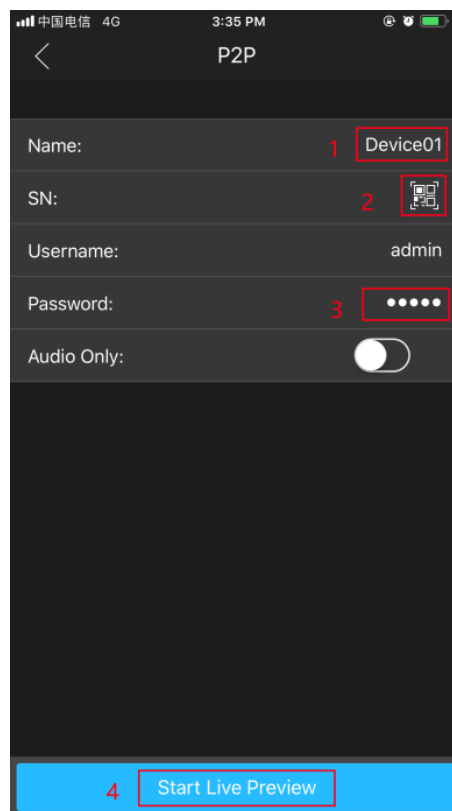
Step 1 Run the app, and then select **DOOR** on the home page. See Figure 5-3.


Figure 5-3



Step 2 Tap the "+" sign to add device, and the tap **Add Device > P2P**. The **P2P** interface is displayed. See Figure 5-4.

Figure 5-4

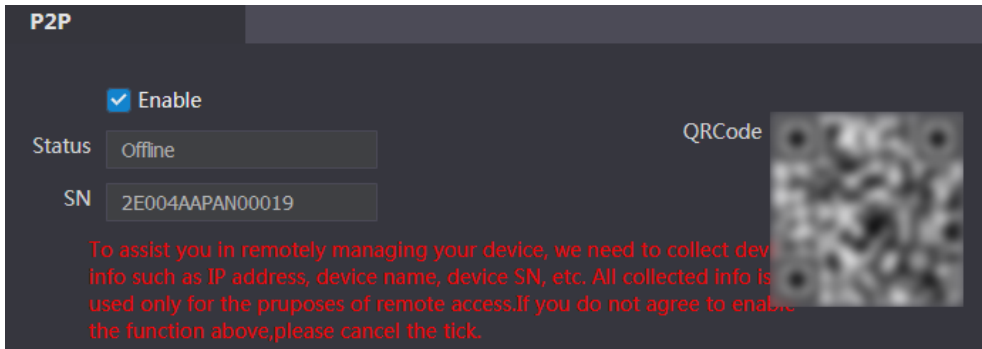


Step 3 Give a name to your target VTO, and then tap the  sign. The mobile phone starts to scan.

Step 4 Log in the web interface of the VTO you need to add, and then select **Network**.

The **P2P** interface is displayed. See Figure 5-5.

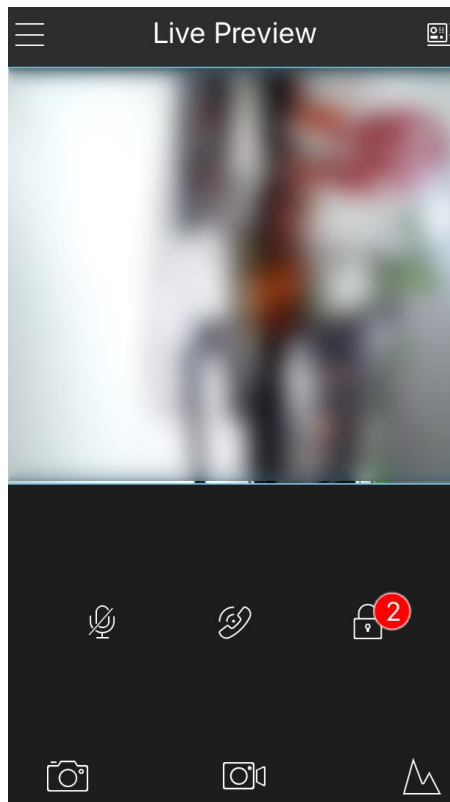
Figure 5-5



Step 5 Scan the QR code with your phone, then then enter the user name and password of its web interface, and then tap **Start Live Preview**.

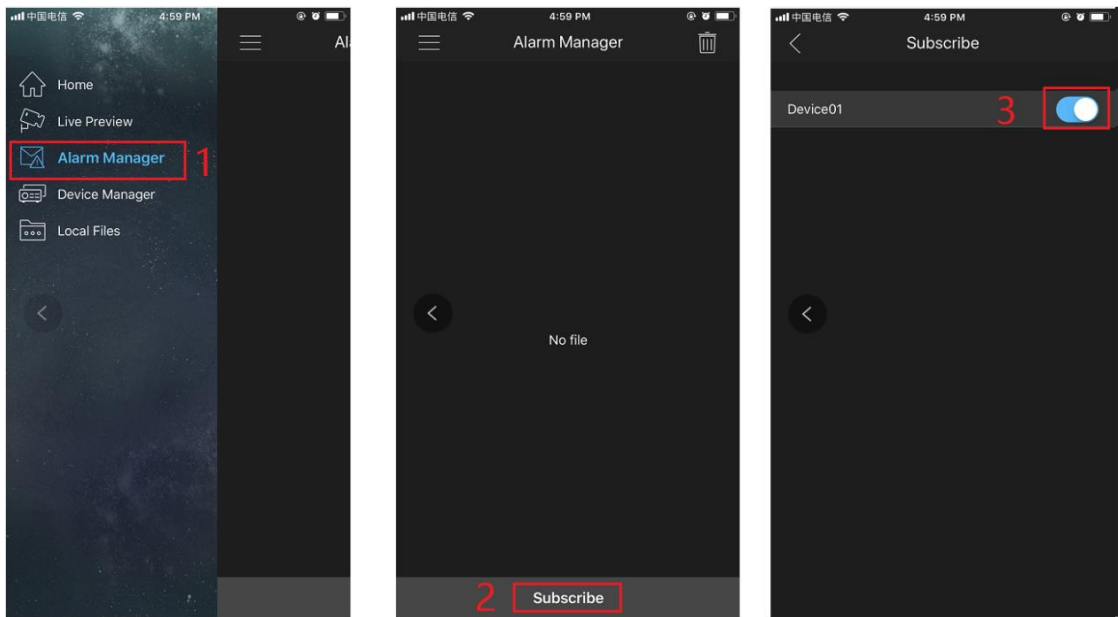
The live video is displayed. And you can also start audio intercom or unlock the door. See Figure 5-6.

Figure 5-6



Step 6 Tap **Alarm Manager > Subscribe**, and then subscribe the VTO you need. See Figure 5-7.

Figure 5-7 Subscribe



When someone is calling you from the subscribed villa VTO, there will be push message on your phone. See Figure 5-8.

Figure 5-8 Push



Packing List

Open the package and check whether all the components are included.

Name	Quantity	Info
VTO	1	
Power adapter	1	
Quick Start Guide	1	
Screw package	1	